

# LY7

## LCD weekly yearly time switch

- Simple program check and edit
- Season program auto change depending on the season setting function
- Added yearly program to the weekly program
- Holiday setting function which can block output to be yielded on holiday and national holiday
- 2 independent control output
- Setting the output possible after power backup
- Flush type and extended type (dual usage) (Install on the DIN rail by the base plate)



# C

Counter /  
Timer

### Suffix code

Suffix	code	Description
LY	<input type="checkbox"/>	LCD weekly yearly timer switch
Dimension	7	DIN 72 X 72 mm
Power supply voltage		100 – 240 V AC 50/60 Hz(dual usage)

### Specification

Power supply voltage	100 – 240 V AC 50/60 Hz(dual usage)	
Allowable voltage variation	±10 % of the power supply voltage	
Power consumption	Approx 4.2 VA (220 V AC 60 Hz)	
Display method	LCD display method (displayable digit : 4 digits, 2 lines) 1st display : character height 12 mm, 2nd display : character height 7 mm	
1 cycle time	Weekly setting : for 1 week (7days), Yearly setting : for 1 year (calendar until 2099)	
Backup time	More than 5 consecutive years (25°C)	
External contact input (BOOT input)	Use the contact such as switch, relay and etc. (But please use the contact that can sufficiently ON/OFF 5 V 0.1 MA)	
setting step	Number of program setting	Weekly program : 64 step, yearly program : 32 step
	Number of season setting	4 seasons (Spring, summer, autumn, winter)
	Number of holidays in one year	16 times
Installation type	Flush panel mount type, and exposed panel mount type(dual usage) Din rail installation and screw fixing	
Cycle error	±15sec/mon(25°C)	
Time error	Less than ±0.01% ±0.05 sec (Setting error, Voltage error, Temperature error)	
Control output	Contact composition	2 independent circuits. OUT1 : SPDT (1c), OUT2 : SPDT (1c)
	Contact capacity	15A 250 V AC (resistive load)
	Life expectancy mechanically	Above 10 million times
	Life expectancy electrically	Above 50 thousand times (250 V AC 15 A resistive load)
Insulation resistance	100 MΩ min (500 V DC mega standard, actuator terminal and exposed non-charged metal part)	
Dielectric strength	2000 V AC 50/60 Hz for 1 min (actuator terminal and exposed non-charged metal part)	
Noise immunity	±2 kV (between the actuating power terminal), square wave shape noise by the noise simulator (Pulse width = 1 us)	

Vibration	Vibration resistance	10 – 55 Hz (for cycle 1 min) 0.75 mm double amplitude for 1 hours each in X, Y and Z
	Malfunction	10 – 55 Hz (for cycle 1 min) 0.5 mm double amplitude for 10 minutes each in X, Y and Z
Output	Shock resistance	300 ㉫ 3 times each in X, Y and Z directions
	Malfunction	100 ㉫ 3 times each in X, Y and Z directions
Ambient temperature		-10 ~ 55 ㉫ (with no icing)
Storage temperature		-20 ~ 65 ㉫ (with no icing)
Ambient humidity		35 ~ 85 % RH
Weight		Approx. 275 g (excluded the weight of box)

## ●● Function explanation

### ■ Operation function explanation

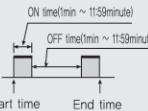
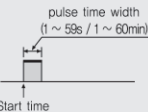
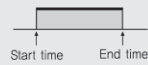
Lists	Description
<p>Weekly timer operation</p> 	<p>Control the output depending on the set start / end time. (After setting the weekly timer operation and when setting the additional program, users will not be able to use the weekly pulse operation setting.)</p> <ul style="list-style-type: none"> <li>• Minimum setting time unit : 1 min.</li> <li>• Weekly timer operation setting is composed of 2 STEP.                             <ul style="list-style-type: none"> <li>– Start day/start time (1 STEP)    – end day/end time (1 STEP)</li> </ul> </li> </ul>
<p>Weekly cycle operation</p> 	<p>It repeats the ON/OFF operation with the range of ON time and OFF time within the time from start set time to the end set time. (After setting the cycle operation and when setting the additional setting, users will not be able to use the weekly pulse operation setting.)</p> <ul style="list-style-type: none"> <li>• Minimum set time unit : 1 min.    • ON time range, OFF time range : 00:01 ~ 11:59</li> <li>• Weekly cycle operation setting is composed of 4 STEP.                             <ul style="list-style-type: none"> <li>– Start day/start time (1 STEP)    – End day/end time (1 STEP)</li> <li>– ON time range (1 STEP)    – OFF time range (1 STEP)</li> </ul> </li> </ul>
<p>Weekly pulse operation</p> 	<p>Operate the output as an ON operation which starts from the start set time until it reaches a certain period of time. (After setting the weekly pulse operation and when setting the additional setting, users will not be able to use the weekly timer operation setting and weekly cycle operation setting)</p> <ul style="list-style-type: none"> <li>• Pulse time range : 1 ~ 59 s (1 sec unit), 1 ~ 60 min (1 min unit)</li> <li>• Weekly pulse operation setting is composed of 2 STEP.                             <ul style="list-style-type: none"> <li>– start day/start time (1 STEP)    – pulse time range (1 STEP)</li> </ul> </li> </ul>
<p>Yearly timer operation</p> 	<p>It controls the output depending on the start/end time which had been set in between the start time and the end time (Possible to set the operation every year)</p> <ul style="list-style-type: none"> <li>• Able to add the yearly timer operation to the weekly timer operation.</li> <li>• Minimum set time unit : 1min.    • Yearly timer operation is composed of 4 STEP.                             <ul style="list-style-type: none"> <li>– Start day (1 STEP)    – End day (1 STEP)</li> <li>– Start time (1 STEP)    – End time (1 STEP)</li> </ul> </li> </ul>

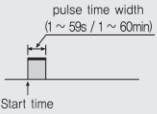
<p>Yearly pulse operation</p> 	<p>Operate the output as an ON operation for a curtail period of time at the start time that had been set in between of start time and end time. (Operation setting function yearly)</p> <ul style="list-style-type: none"> <li>• Able to add the yearly pulse operation to the weekly pulse operation.</li> <li>• – Pulse range : 1 ~ 59 s (1sec unit), 1 ~ 60 min (1min unit) <ul style="list-style-type: none"> <li>– 1sec → 2sec • • • 59sec → 1min → 2min • • • 59min → 60min → 1sec • • •</li> </ul> </li> <li>• Yearly pulse operation setting is composed of 4 STEP. <ul style="list-style-type: none"> <li>– Start day (1 STEP)      – End day (1 STEP)</li> <li>– Start time (1 STEP)    – Pulse time range (1 STEP)</li> </ul> </li> </ul>
<p>Current time setting</p>	<p>Applied when setting the current time.</p> <ul style="list-style-type: none"> <li>• When using this for the first time or performing the reset function, the screen will be switched to the time adjusting screen so please set to the current time and use it.</li> </ul>
<p>Holiday setting</p>	<p>By setting the date for weekend, national holiday and etc, users can set the holiday (non-operating day) temporarily without revising the program.</p> <ul style="list-style-type: none"> <li>• Possible to set holiday every year</li> </ul>
<p>Season setting</p>	<p>Able to set automatic change of weekly program operation depending on season change by setting season period</p> <ul style="list-style-type: none"> <li>• Use it same as the yearly operation setting.</li> <li>• When changing the season setting, all of the weekly programs will be deleted.</li> </ul>
<p>Output when power is backed up</p>	<p>Assigns the output state when power is backed up.</p> <ul style="list-style-type: none"> <li>• AUTO setting : when re-supplying in the power after experiencing the power failure, output will be operated depending on the set program.</li> <li>• Normal set : when re-supplying in the power after experiencing the power failure, <b>POW</b> POW indication will start to flicker and disregarding the set program, output will maintain the OFF state. (with the BOOT input, output will be operated by following the set program)</li> </ul>
<p>Summer time switch</p>	<p>Summer time setting can be set automatically and manually .</p> <ul style="list-style-type: none"> <li>• Current time ⇔ switch to current time + 1h (summer time)</li> </ul>
<p>Program check</p>	<p>Applied when needs to check the program setting information in the operation mode state.</p> <ul style="list-style-type: none"> <li>• Operated depending on the program setting information and output does not get blocked</li> <li>• Displayed in the order of program input</li> <li>• If there are no key input for 1 min then it will return to the operation mode automatically</li> </ul>
<p>Program edit</p>	<p>Able to edit and delete the program setting</p> <ul style="list-style-type: none"> <li>• Unable to revise the setting for timer operation, pulse operation and cycle operation.</li> <li>• Displayed in the order of program input.</li> </ul>
<p>Program test</p>	<p>Check the day and time for actual output to start and end for 1 week.</p> <ul style="list-style-type: none"> <li>• within the same output program, if program and operation time are duplicated then it may be ignored.</li> <li>• It continuously displays from the output 1 until the date reaches 1 week in the consecutive operation time order.</li> </ul>

■ Output operation

- Operation 1 : When inputting the additional weekly program ② to the weekly set program ①, output will be operated just like an operation 1.
- Operation 2 : When inputting the additional yearly program ② to the yearly set program ①, output will be operated just like an operation 2.
- Operation 3 : When inputting the additional yearly program ① to the weekly set program ①, output will be operated just like an operation 3.
- Operation 4 : When inputting the additional weekly program ② to the yearly set program ②, output will be operated just like an operation 4.

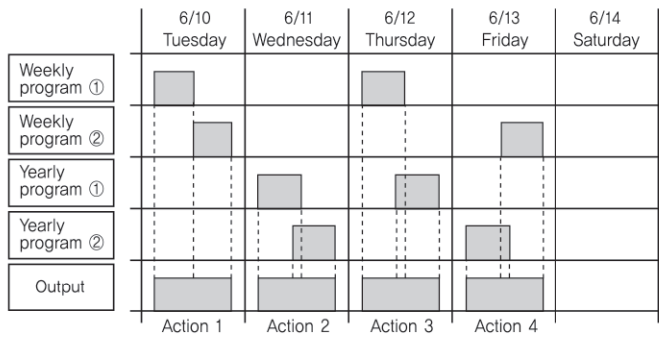

🔍 Front panel composition

■ LCD display

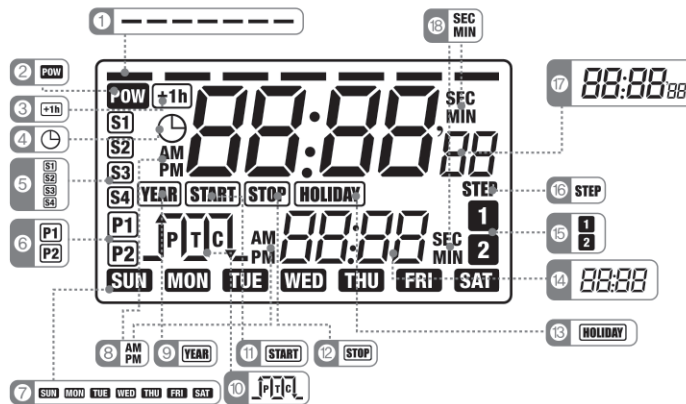

Lists	Description
① Day indicator	Indicates current day and the set day cursor
② Power failure backup output indication	when re-supplying in the power after experiencing the power failure, the return or backup input state will be displayed
③ Summer time indication	Indicates in the summer time
④ Time adjustment indicator	Indicated when setting the current time
⑤ Season indication	Indicates the season
⑥ Setting port number indication	Indicates the port number that has been set
⑦ Set day indicator	Indicates the set day
⑧ AM/PM indicator	Indicates AM/PM 12h
⑨ Yearly indicator	Indicates the yearly program setting status

⑩ Operation state indicator	Indicates the timer, pulse, cycle action setting and indicates the next action state operation ※ Timer action :  Start time :  End time : ※ Pulse action :  Pulse time width : ※ Cycle action :  Start time :  End time :
⑪ Start date indicator	Indicated when setting the yearly start date
⑫ End date indicator	Indicated when setting the yearly end date
⑬ Holiday indicator	Indicated on the holiday or indicated when setting the holiday
⑭ 2nd indicator	Indicates current month, date and next operation time
⑮ Output action indicator	Indicates the output number which of output action being ON
⑯ Remaining step indicator	When setting the program, it displays the number of remaining steps
⑰ 1st indicator	Indicates current time and indicated when setting the program
⑱ Pulse width unit indicator	Indicates the pulse range time unit within the pulse operation

■ Front panel

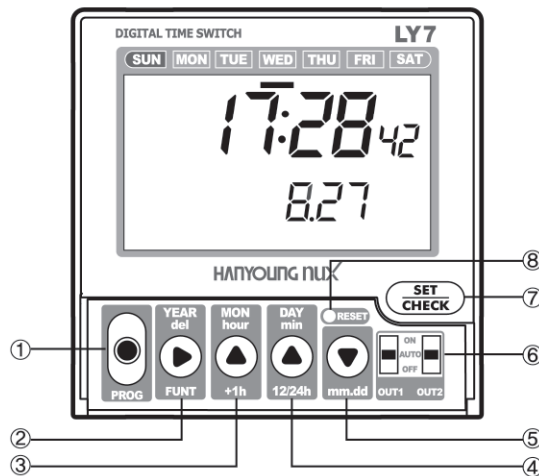

Lists	Description
① PROG (program key)	Applied when setting the program (weekly/yearly program setting and editing, deleting, inspecting)
② FUNT (func wire key)	FUNT : applied when setting the function (time setting, holiday setting, season setting, summer time setting, power failure backup setting) YEAR : press UP key to set the year (yearly setting) Del : applied as the program delete key in the weekly/yearly program setting edit mode. SHIFT : applied as the shift key when setting the weekly program operation date setting.
③ +1h key	+1h : used when applying the summer time manually (operation mode) MON : press UP key to set the month (yearly setting) Hour : press UP key to set an hour.
④ 12/24h key	12/24h : applied as the time changing key (operation mode) – Display the current time as 24h and convert to the AM/PM 12h. DAY : press UP key to set the day (yearly setting) Min : press UP key to set the min.

⑤ mm.dd key	mm.dd : applied as the key to change the 2nd display [current date display (month, day)] to the [next operation time display] (operation mode state) DOWN : apply as the DOWN KEY regarding the previous time value.
⑥ Output setting switch	ON : Forcedly turn ON the output disregarding the program setting information. AUTO : Output operated depending on the program setting information. OFF : Forcedly turn OFF the output operation disregarding the program setting information.
⑦ SET/CHECK key	SET : Use SET key in the setting mode. CHECK : used as the weekly/yearly program check key in the operation mode.
⑧ RESET key	Reset (initialize) all settings including the current time.

### ●● Flush type/exposed type converting method

- Unloosen the terminal tightening volt from the case, hold the case/terminal and pull them in the direction of up and down just like an image provided in the below then it will be converted to the panel exposed type.
- In order to fix the terminal, please retighten the fixing volt, switch left/right side terminal volt and then tighten them.
- When switching the type from panel exposed type to the panel flush type, please follow the image provided in the below but only in a reverse order

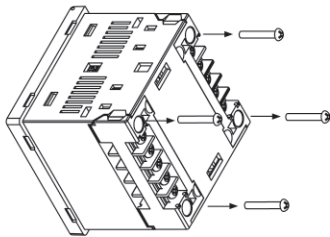

1. Unloosen the terminal fixing bolt (panel flush type)

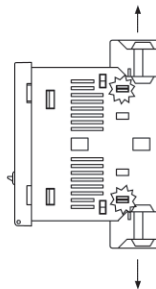

2. Pull the terminal in the direction of up and down.

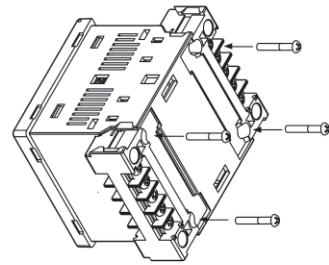

3. Retighten the terminal fixing bolt.

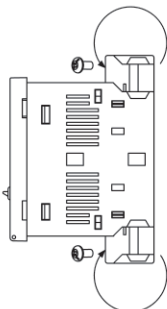

4. Switch left/right side terminal volt and tighten them.

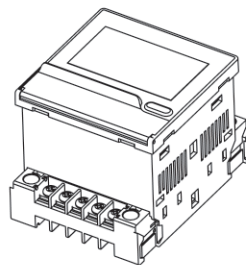

5. Panel exposed type

## Dimension and panel cutout (Unit : mm)

### ● Flush panel type

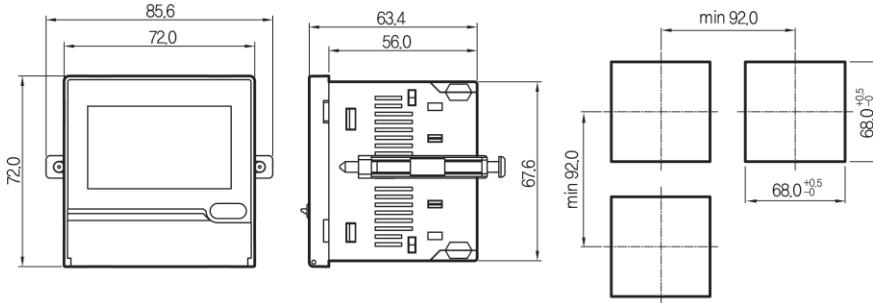

### ● Exposed type

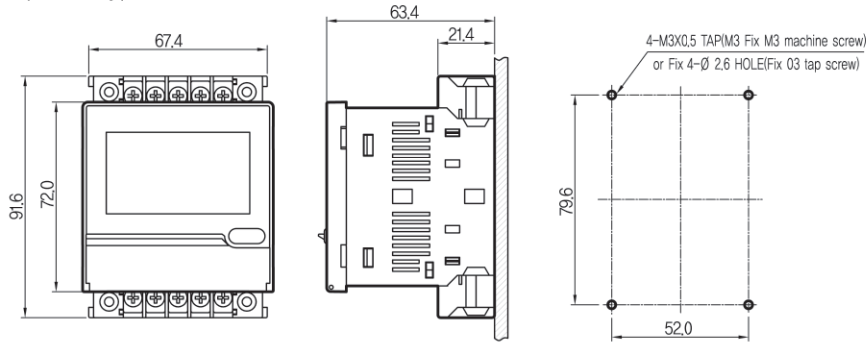

### ● DIN rail mounting type

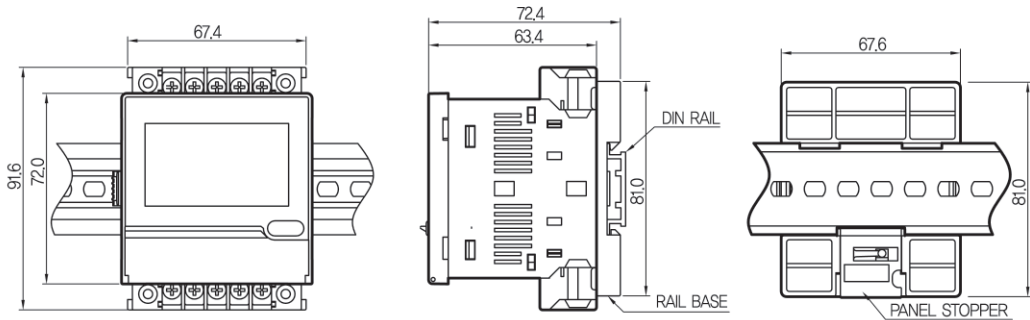

### ● Din rail base installing and uninstalling method

1. When installing the rail base, firstly mount the indicated number ① and press the indicated number ② just like an image provided below.
2. When uninstalling from the rail base, pull out the indicated number ② by pressing the CASE fixing button.

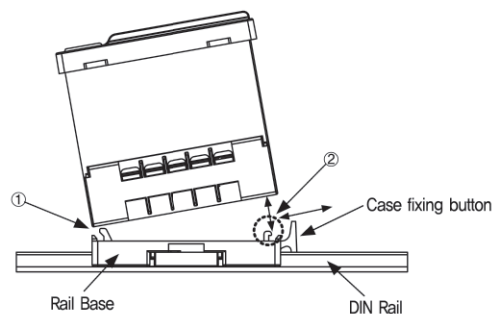

## Connection diagram

### Terminal arrangement

Output relay (OUT1, OUT2) are internally separated from the power line.

Output contact capacity is 15A 250V AC (inductive load) so do not let the over current to flow in and out and use standard wiring method.

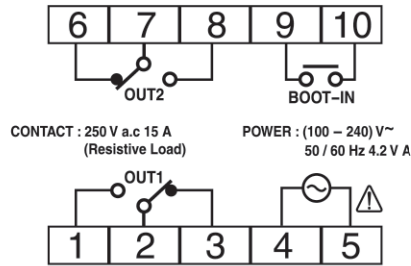

C  
Counter /  
Timer

### External contact input connection

In case that set output setting mode to normal setting mode in power failure backup, the output is OFF state. Here supplying external contact input (BOOT-IN) signal will operate as program state

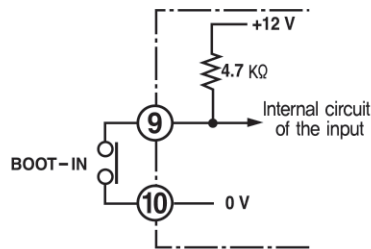

### Example of Power and Output (OUT1, OUT2) connection

• In case when power and load power are different

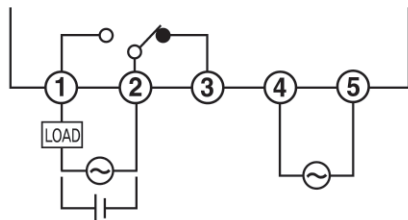

• In case when power and load power are same

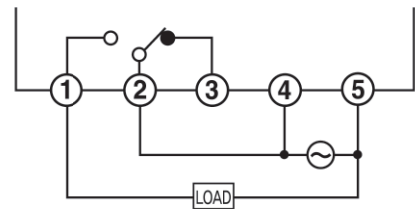

When setting the power failure backup mode as normal mode, the output will become OFF when power backup. Here, supplying in the external contact input (BOOT-IN) will make it operate as program state.



## Parameter formation

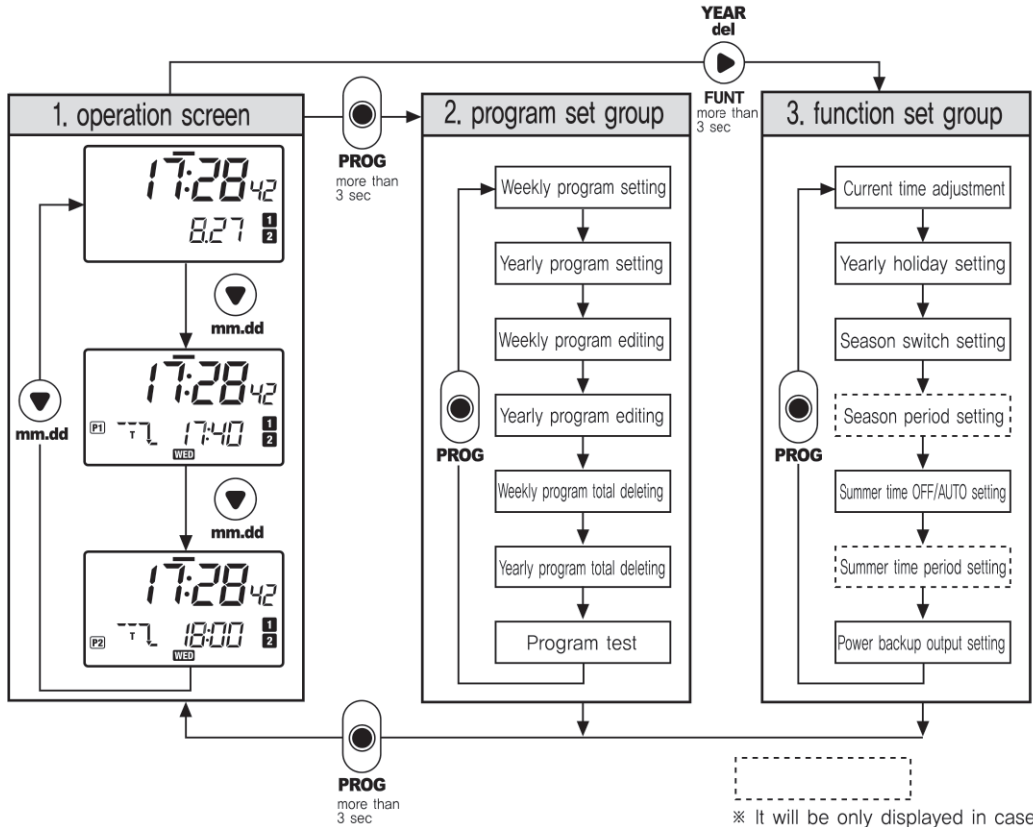

※ It will be only displayed in case Season switch setting is "ON".  
 ※ It will be only displayed in case of Summer time "AUTO".

## Setting group formation

### Program set group formation

- |  |                                                                                             |  |                                                                                                         |
|--|---------------------------------------------------------------------------------------------|--|---------------------------------------------------------------------------------------------------------|
|  | ① Operation mode<br>• Display current time and day                                          |  | ⑤ Yearly program revise and delete mode<br>• "YEAR" Flickers<br>• Display yearly total STEP             |
|  | ② Weekly program set mode<br>• "YEAR" Flickers<br>• Display weekly remaining STEP           |  | ⑥ Weekly program total delete mode<br>• "YEAR" Flickers<br>• Delete weekly program 1 and 2 individually |
|  | ③ Yearly program set mode<br>• "YEAR" Flickers<br>• Display yearly remaining STEP           |  | ⑦ Yearly program total delete mode<br>• "YEAR" Flickers<br>• Delete yearly program 1 and 2 individually |
|  | ④ Weekly program revise and delete mode<br>• "YEAR" Flickers<br>• Display weekly total STEP |  | ⑧ Program test mode<br>• "EE5L" Flickers<br>• Display 1 week continuously in the operation order        |

■ Function set group formation

- |                                                                                                                                                                                                                                                                                                                                                                                                 |                                                                                                                                                                                                                                                                                                                                                                                                                                                                                                                                                                                                                                                                                                                                                                                                                                                                                                                                                                                                                                                                                                                                                                                                                                                                                                 |                                                                                                                                                                                                                               |                                                                                                                                                                                                                                                                                                                                                                                                                                                                                                                                                                                                                                                                                                                                                                                                                                                                                                                                                                                                                                                                                           |
|-------------------------------------------------------------------------------------------------------------------------------------------------------------------------------------------------------------------------------------------------------------------------------------------------------------------------------------------------------------------------------------------------|-------------------------------------------------------------------------------------------------------------------------------------------------------------------------------------------------------------------------------------------------------------------------------------------------------------------------------------------------------------------------------------------------------------------------------------------------------------------------------------------------------------------------------------------------------------------------------------------------------------------------------------------------------------------------------------------------------------------------------------------------------------------------------------------------------------------------------------------------------------------------------------------------------------------------------------------------------------------------------------------------------------------------------------------------------------------------------------------------------------------------------------------------------------------------------------------------------------------------------------------------------------------------------------------------|-------------------------------------------------------------------------------------------------------------------------------------------------------------------------------------------------------------------------------|-------------------------------------------------------------------------------------------------------------------------------------------------------------------------------------------------------------------------------------------------------------------------------------------------------------------------------------------------------------------------------------------------------------------------------------------------------------------------------------------------------------------------------------------------------------------------------------------------------------------------------------------------------------------------------------------------------------------------------------------------------------------------------------------------------------------------------------------------------------------------------------------------------------------------------------------------------------------------------------------------------------------------------------------------------------------------------------------|
| <div style="border: 1px solid black; padding: 2px; margin-bottom: 10px;"> </div> <div style="border: 1px solid black; padding: 2px; margin-bottom: 10px;"> </div> <div style="border: 1px solid black; padding: 2px; margin-bottom: 10px;"> </div> <div style="border: 1px solid black; padding: 2px; margin-bottom: 10px;"> </div> <div style="border: 1px solid black; padding: 2px;"> </div> | <p>① <b>Operation mode</b></p> <ul style="list-style-type: none"> <li>• Display current time and day</li> </ul> <p>② <b>Time adjustment setting</b></p> <ul style="list-style-type: none"> <li>• " ☉ " Flickers</li> <li>• Set current year/month/day 「00 year, 00 month, 00 day」</li> <li>• Set current time 「00 hour, 00 min」</li> </ul> <p>③ <b>Holiday setting</b></p> <ul style="list-style-type: none"> <li>• " HdRY " Flickers</li> <li>• Used when setting the holiday temporarily (non-operating day)</li> <li>• Number of holiday setting : 16 times</li> <li>• Set the start year/month/day,</li> <li>• set the end year/month/day</li> <li>• Possible to set every year</li> </ul> <p>④ <b>Season selection</b></p> <ul style="list-style-type: none"> <li>• " SE5n " Flickers</li> <li>• Set seasons by considering the weekly program (Cautious) when changing the season, settings in the weekly program will be deleted.</li> </ul> <p>⑤ <b>Set the period for season switching</b></p> <ul style="list-style-type: none"> <li>• Displayed when setting the SE5n mode as ON</li> <li>• Select the season that you want to set a period on</li> <li>• Number of season setting : 4 seasons(S1, S2, S3, S4)</li> <li>• Set the start month/day • Set the end month/day</li> </ul> | <div style="border: 1px solid black; padding: 2px; margin-bottom: 10px;"> </div> <div style="border: 1px solid black; padding: 2px; margin-bottom: 10px;"> </div> <div style="border: 1px solid black; padding: 2px;"> </div> | <p>⑥ <b>Summer time switching automatically</b></p> <ul style="list-style-type: none"> <li>• " dSt " Flickers</li> <li>• Current time ↔ current time +1h (summer time)</li> <li>• AUTO : Summer time auto switching (change depending on the setting period)</li> <li>• OFF : Summer time manual switching (change depending on the +1h key)</li> </ul> <p>⑦ <b>Summer time "AUTO" operation setting</b></p> <ul style="list-style-type: none"> <li>• Displayed when setting the " dSt " mode as AUTO</li> <li>• Summer time auto switching period setting             <ul style="list-style-type: none"> <li>– Set the start month/day/hour</li> <li>– Set the end month/day/hour</li> </ul> </li> </ul> <p>⑧ <b>Power backup setting</b></p> <ul style="list-style-type: none"> <li>• " boot " Flickers</li> <li>• Assign the output state when power is backed up             <ul style="list-style-type: none"> <li>– NOR : Output will be maintained as OFF state disregarding the set program</li> <li>– AUTO : Output operated depending on the set program</li> </ul> </li> </ul> |
|-------------------------------------------------------------------------------------------------------------------------------------------------------------------------------------------------------------------------------------------------------------------------------------------------------------------------------------------------------------------------------------------------|-------------------------------------------------------------------------------------------------------------------------------------------------------------------------------------------------------------------------------------------------------------------------------------------------------------------------------------------------------------------------------------------------------------------------------------------------------------------------------------------------------------------------------------------------------------------------------------------------------------------------------------------------------------------------------------------------------------------------------------------------------------------------------------------------------------------------------------------------------------------------------------------------------------------------------------------------------------------------------------------------------------------------------------------------------------------------------------------------------------------------------------------------------------------------------------------------------------------------------------------------------------------------------------------------|-------------------------------------------------------------------------------------------------------------------------------------------------------------------------------------------------------------------------------|-------------------------------------------------------------------------------------------------------------------------------------------------------------------------------------------------------------------------------------------------------------------------------------------------------------------------------------------------------------------------------------------------------------------------------------------------------------------------------------------------------------------------------------------------------------------------------------------------------------------------------------------------------------------------------------------------------------------------------------------------------------------------------------------------------------------------------------------------------------------------------------------------------------------------------------------------------------------------------------------------------------------------------------------------------------------------------------------|

C

Counter / Timer

🔗 Program setting (program set group)

■ Current time adjusting method

(Setting example) set the current time as 2008 9/10 13:20

- |                                                                                                                                                                                                                                                                                                                |                                                                                                                                                                                                                                                                                                                                                                                                                                                                                                                                                                                                                                                                                                                                                                                                                                                                                                                                                                                                                                                                                                                                                                                                                                                 |
|----------------------------------------------------------------------------------------------------------------------------------------------------------------------------------------------------------------------------------------------------------------------------------------------------------------|-------------------------------------------------------------------------------------------------------------------------------------------------------------------------------------------------------------------------------------------------------------------------------------------------------------------------------------------------------------------------------------------------------------------------------------------------------------------------------------------------------------------------------------------------------------------------------------------------------------------------------------------------------------------------------------------------------------------------------------------------------------------------------------------------------------------------------------------------------------------------------------------------------------------------------------------------------------------------------------------------------------------------------------------------------------------------------------------------------------------------------------------------------------------------------------------------------------------------------------------------|
| <div style="border: 1px solid black; padding: 2px; margin-bottom: 10px;"> </div> <div style="border: 1px solid black; padding: 2px; margin-bottom: 10px;"> </div> <div style="border: 1px solid black; padding: 2px; margin-bottom: 10px;"> </div> <div style="border: 1px solid black; padding: 2px;"> </div> | <p>① <b>Enter into the current time set mode</b></p> <ul style="list-style-type: none"> <li>• Pressing the <b>FUNT</b> key for more than 3 sec within the operation mode will enter into the "time set mode." ( ☉ flickers)</li> <li>• Press the <b>SET</b> key</li> </ul> <p>② <b>Set current year, month, day</b></p> <ul style="list-style-type: none"> <li>• Set year, month and day by pressing the <b>YEAR</b>, <b>MON</b> and <b>DAY</b> key but ▼ key is applied when decreasing the previous value.</li> <li>• Once setting the current year, month and day are completed, press the <b>SET</b> key.</li> </ul> <p>③ <b>Set current time</b></p> <ul style="list-style-type: none"> <li>• Set hour and min by pressing the <b>hour</b> and <b>min</b> key but ▼ key is applied when decreasing the previous time.</li> <li>• Once setting the current time is completed, press the <b>SET</b> key.</li> </ul> <p>④ <b>Return to the operation mode</b></p> <ul style="list-style-type: none"> <li>• Since setting has been completed, pressing the <b>PROG</b> key for more than 3 sec will confirm the setting and return to the operation mode.</li> <li>• When revising the setting, please repeat the given steps (1~4)</li> </ul> |
|----------------------------------------------------------------------------------------------------------------------------------------------------------------------------------------------------------------------------------------------------------------------------------------------------------------|-------------------------------------------------------------------------------------------------------------------------------------------------------------------------------------------------------------------------------------------------------------------------------------------------------------------------------------------------------------------------------------------------------------------------------------------------------------------------------------------------------------------------------------------------------------------------------------------------------------------------------------------------------------------------------------------------------------------------------------------------------------------------------------------------------------------------------------------------------------------------------------------------------------------------------------------------------------------------------------------------------------------------------------------------------------------------------------------------------------------------------------------------------------------------------------------------------------------------------------------------|

- When running the program for the first time or after resetting the program, it will display the time adjusting screen so please set the current time by following the steps 2 and 3.
- Pressing the UP and DOWN key for more than 1 sec will change the setting quickly.
- Allowable range of current time setting is maximum 2099 12/31.

## ■ Normal timer operation

Example) Output 1 operates as ON from Monday to Friday at 8:30 to 17:40 Parameter

Sunday	Monday	Tuesday	Wednesday	Thursday	Friday	Saturday
	■	■	■	■	■	
	8:30 ~ 17:40	8:30 ~ 17:40	8:30 ~ 17:40	8:30 ~ 17:40	8:30 ~ 17:40	



### ① Press enter into the weekly program setting

- Press the **PROG** key for more than 3sec within the operation mode state then **YEEK** will flicker. Once flickers, please press the **SET** key



### ② Port 1 and port 2 setting

- When setting the port, set by pressing the **▲** or **▼** key.
- Once **[P1]** (port 1) flickers, press the **SET** key.



### ③ Operation mode setting

- Since it is in the timer operation mode, press the **SET** key right away (when changing the operation setting, press the **▲** or **▼** key)



### ④ Season setting

- When setting the season, press **▲** or **▼** key to set.
- Once "**S1**" starts to flicker, press the **SET** key. But only able to set when season switching is set as ON. If season switching is not set as ON, it will go to the start day setting.



### ⑤ Start day setting

- Because the position of cursor (—) is on the Sunday (SUN), turn OFF **SUN** that is on the set day position by pressing the **▲** or **▼** key
- After moving the position of cursor to the Saturday (SAT) by pressing the **▶** key, turn off **SAT** that is on the set day position by pressing **▲** or **▼** key.
- Once the start day setting is completed, press the **SET** key



### ⑥ Start time setting

- Set the start time by using the **hour** and **min** key but **▼** key is only used when decreasing the previous value.
- Once the start time setting is completed, press the **SET** key.



### ⑦ End day setting

- End day is same as the start day so press the **SET** key. (Follow the start day setting ⑤)



### ⑧ End time setting

- Set the end time by using the **hour** and **min** key but **▼** key is only used when decreasing the previous value.
- Once the end time setting is completed, press the **SET** key



### ⑨ Return the weekly program setting

- Press the **PROG** key for more than 3 sec in order to return to the operation mode.

- Pressing the UP and DOWN key for more than 1 sec will change the time value quickly.
- When adding additional programs to the set program, please repeat steps from ② to ⑨
- Weekly timer setting is composed of 2 STEP and once setting is completed then it will display number of remaining STEP that can be set

■ Days timer operation

Example) Out 1 operates continuously as ON from Mon ~ Fri 17:40

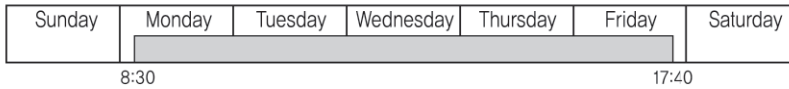

① Enter into the weekly program setting

- Pressing the **PROG** key for more than 3 sec within the operation mode will flicker the " YEEU ". Here, press the **SET** key.



② Port 1 and port 2 setting

- When setting the port, set by pressing the ▲ or ▼ key.
- Once **P1** (port 1) flickers, press the **SET** key.



③ Operation mode setting

- Since it is in the timer operation mode, press the **SET** key right away (when changing the operation setting, press the ▲ or ▼ key)



④ Start day setting

- Because the position of cursor ( - ) is on the Sunday (SUN), turn OFF **SUN** that is on the set day position by pressing the ▲ or ▼ key.
- Shift the position of cursor Tuesday to the Saturday by using ► key and turn off from the Tuesday to the Saturday
- Once the start day setting is completed, press the **SET** key.



⑤ Start time setting

- Set the start time by using the **hour** and **min** key but ▼ key is used when decreasing the previous value.
- Once the start time setting is completed, press the **SET** key.



⑥ End day setting

- Shift the position of cursor ( - ) to the Monday (MON) by using ► key and turn off **MON** that is on the set day position by pressing ▲ or ▼ key.
- Shift the position of cursor to the Saturday (SAT) and turn on **FRI**
- Once the end day setting is completed, press the **SET** key.



⑦ End time setting

- Set the end time by using the **hour** and **min** key but ▼ key is only used when decreasing the previous value.
- Once the end time setting is completed, press the **SET** key



⑧ Return the weekly program setting

- Press the **PROG** key for more than 3 sec in order to return to the operation mode.

- Pressing the UP and DOWN key for more than 1 sec will change the setting quickly.
- When adding additional programs to the set program, please repeat steps from ② to ⑧.

Caution) Please do not overlap operation time with other programs' one, when setting to add program within the same output port.

## ■ Next day timer operation

Example) Output 1 ON operation from Mon ~ Fri 20:30 to the next day 6:30

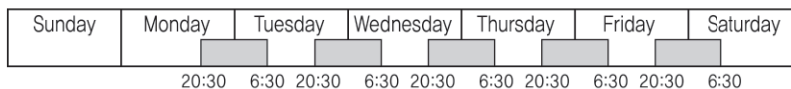

### ① Enter into the weekly program setting

- Pressing the **PROG** key for more than 3 sec within the operation mode will flicker the "4EEU". Here, press the **SET** key.



### ② Port 1 and port 2 setting

- When setting the port, set by pressing the ▲ or ▼ key.
- Once [P1] (port 1) flickers, press the **SET** key.



### ③ Operation mode setting

- Since it is in the timer operation mode, press the **SET** key right away (when changing the operation setting, press the ▲ or ▼ key)



### ④ Start day setting

- Because the position of cursor ( - ) is on the Sunday (SUN), turn OFF **SUN** that is on the set day position by pressing the ▲ or ▼ key.
- Shift the position of cursor to the Saturday (SAT) by using ► key and turn off **SAT** that is on the set day position by pressing ▲ or ▼ key.
- Once the start day setting is completed, press the **SET** key.



### ⑤ Start time setting

- Set the start time by using the **hour** and **min** key but ▼ key is used when decreasing the previous value.
- Once the start time setting is completed, press the **SET** key.



### ⑥ End day setting

- Shift the position of cursor ( - ) to the Monday (MON) by using ► key and turn off **MON** that is on the set day position by pressing ▲ or ▼ key.
- Shift the position of cursor to the Saturday (SAT) and turn on **SAT**
- Once the end day setting is completed, press the **SET** key.



### ⑦ End time setting

- Set the end time by using the **hour** and **min** key but ▼ key is only used when decreasing the previous value.
- Once the end time setting is completed, press the **SET** key



### ⑧ Return the weekly program setting

- Press the **PROG** key for more than 3 sec in order to return to the operation mode.

- Pressing the UP and DOWN key for more than 1 sec will change the setting quickly.
- When adding additional programs to the set program, please repeat steps from ② to ⑧.

■ Weekly pulse operation

Example) Output 2 ON operation from Monday to Friday at 8:50 for only 10 sec

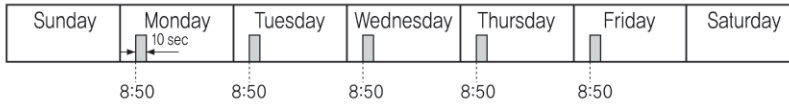

① Enter into the weekly program setting

- Pressing the **PROG** key for more than 3 sec within the operation mode will flicker the "YEEH". Here, press the **SET** key.



② Port 1 and port 2 setting

- When setting the port, set by pressing the ▲ or ▼ key.
- Once **P2** (port 2) flickers, press the **SET** key.



③ Operation mode setting

- Since it is in the timer operation mode, Set as pulse operation mode by pressing the ▲ or ▼ key. Once the pulse operation setting is completed press the set key



④ Season setting

- When setting the season, press ▲ or ▼ key to set it
- Once **S1** starts to flicker, press the **SET** key. But, able to set when season switching is set as ON. If season switching is not set as ON, it will go to the start day setting.



⑤ Start day setting

- Because the position of cursor ( - ) is on the Sunday (SUN), turn OFF **SUN** that is on the set day position by pressing the ▲ or ▼ key.
- Shift the position of cursor to the Saturday (SAT) by using ► key and turn off **SAT** that is on the set day position by pressing ▲ or ▼ key.
- Once the start day setting is completed, press the **SET** key.



⑥ Start time setting

- Set the start time by using the **hour** and **min** key but ▼ key is only used when decreasing the previous value.
- Once the start time setting is completed, press the **SET** key.



⑦ Pulse time range setting

- Set the pulse time range by using the **min** key, but ▼ key is only used when decreasing the previous value.
- Once pulse time range setting is completed, press the **SET** key.



⑧ Return the weekly program setting

- Press the **PROG** key for more than 3 sec in order to return to the operation mode.

- Pressing the UP and DOWN key for more than 1 sec will change the setting quickly.
- When adding additional programs to the set program, please repeat steps from ② to ⑧ (Cautious) If the weekly pulse operation is set within the same output port, it cannot use the weekly timer and weekly cycle operation setting when setting the additional program.
- Pulse time range: 1 ~ 59 s (1 sec unit), 1 ~ 60 min (1 min unit)  
1s → 2s → ... → 59s → 1m → ... → 59m → 60m → 1s → ...
- Weekly pulse setting is composed of 2 STEP and once setting is completed then it will display number of remaining STEP that can be set



## ■ Weekly cycle operation

Example) From Monday to Friday at 9:00 to 18:00, it repeats following operation. Repeatedly output ON for 10 min and output OFF for 50 min

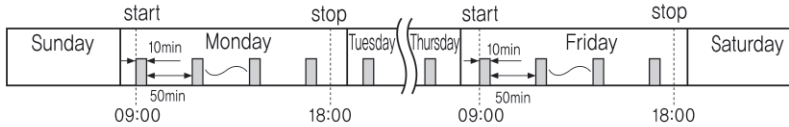

### ① Enter into the weekly program setting

- Pressing the **PROG** key for more than 3 sec within the operation mode will flicker the "YEEH". Here, press the **SET** key.



### ② Port 1 and port 2 setting

- When setting the port, set by pressing the ▲ or ▼ key.
- Once **P1** (port 1) flickers, press the **SET** key.



### ③ Operation mode setting

- Since it is in the timer operation mode, set to cycle operation mode by pressing ▲ or ▼ key



### ④ Season setting

- When setting the season, press ▲ or ▼ key to set it
- Once **S1** starts to flicker, press the **SET** key. But, able to set when season switching is set as ON. If season switching is not set as ON, it will go to the start day setting.



### ⑤ Start day setting

- Because the position of cursor ( - ) is on the Sunday (SUN), turn OFF **SUN** that is on the set day position by pressing the ▲ or ▼ key.
- Shift the position of cursor to the Saturday (SAT) by using ► key and turn off **SAT** that is on the set day position by pressing ▲ or ▼ key.
- Once the start day setting is completed, press the **SET** key.



### ⑥ Start time setting

- Set the start time by using the **hour** and **min** key but ▼ key is only used when decreasing the previous value.
- Once the start time setting is completed, press the **SET** key.



### ⑦ End day setting

- End day is same as the start day so press the **SET** key.
- Follow the start day setting ⑤



### ⑧ End time setting

- Set the end time by using the **hour** and **min** key but ▼ key is only used when decreasing the previous value.
- Once the end time setting is completed, press the **SET** key



### ⑨ ON time range setting

- Set the ON time range by using the **hour** and **min** key but ▼ key is only used when decreasing previous value.
- Once ON time range setting is completed, press the **SET** key.



### ⑩ OFF time range setting

- Set the OFF time range by using the **hour** and **min** key but ▼ key is only used when decreasing previous value.
- Once OFF time range setting is completed, press the **SET** key



### ⑪ Return the weekly program setting

- Press the **PROG** key for more than 3 sec in order to return to the operation mode.

- Pressing the UP and DOWN key for more than 1 sec will change the time value quickly.
- When adding additional programs to the set program, please repeat steps from ② to ⑩ (Cautious) if the weekly timer operation and weekly cycle operation is set, it cannot use the weekly pulse operation when setting the additional program.
- Weekly pulse setting is composed of 4 STEP and once setting is completed then it will display the number of remaining STEP that can be set

■ Yearly timer operation

Example) From 6/7 to 6/8, output 1 ON at 18:00 and output 1 OFF at 19:40 for every year

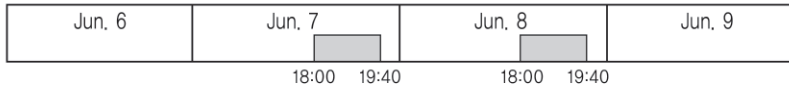

- ① Enter into the Yearly program setting
- Within the operation mode, press the **PROG** key for more than 3 sec to enter into the set mode and then press the **PROG** key one more time shortly then **YEAR** will start to flicker. Here, press the **SET** key.

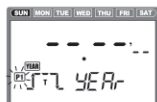

- ② Port 1 and port 2 setting
- When setting the port, set by pressing the ▲ or ▼ key.
  - Once **P1** (port 1) flickers, press the **SET** key.



- ③ Operation mode setting
- Since it is in the timer operation mode, press the **SET** key right away (when changing the operation setting, press the ▲ or ▼ key)



- ④ Set the start year, month and day
- Set the start year, month and day by pressing the **YEAR**, **MON** and **DAY** key but ▼ key is applied when decreasing the previous value.
  - Once setting the start year, month and day are completed, press the **SET** key (Cautious) within the year, the " -- " indication is a setting for every year.



- ⑤ Set the end year, month and day
- Set the end year, month and day by pressing the **YEAR**, **MON** and **DAY** key but ▼ key is applied when decreasing the previous value.
  - Once setting the end year, month and day are completed, press the **SET** key (Cautious) setting the year as the ( -- ) for every year within the start year, month and day will fix the end year as ( -- ) for every year.



- ⑥ Start time setting
- Set the start time by using the **hour** and **min** key but ▼ key is only used when decreasing the previous value.
  - Once the start time setting is completed, press the **SET** key.



- ⑦ End time setting
- Set the end time by using the **hour** and **min** key but ▼ key is only used when decreasing the previous value.
  - Once the end time setting is completed, press the **SET** key



- ⑧ Return the yearly program setting
- Press the **PROG** key for more than 3 sec in order to return to the operation mode.

- Pressing the UP and DOWN key for more than 1 sec will change the time value quickly.
- When setting the year, it can set the year up to 2 years from the current year.  
Example) if current year is 2008, it can be set as follows.  
-- => 08 => 09 => 10 => -- => 08 => . . .
- When adding additional programs to the set program, please repeat steps from ② to ⑧
- In the state where yearly program is being set, it can additionally set the weekly program.
- Yearly timer setting is composed of 4 STEP and once setting is completed then it will display the number of remaining STEP that can be set.





## ■ Yearly pulse operation

Example) Output 2 ON operation for only 10 sec from 2008 9/8 to 2008 9/10 at 17:40

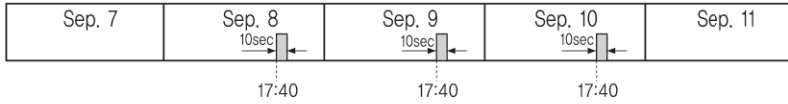

### ① Enter into the Yearly program setting

- Within the operation mode, press the **PROG** key for more than 3 sec to enter into the program set mode and then press the **PROG** key one more time shortly then **YEAR** will start to flicker. Here, press the **SET** key.



### ② Port 1 and port 2 setting

- When setting the port, set by pressing the  $\blacktriangle$  or  $\blacktriangledown$  key.
- Once **P2** (port 2) flickers, press the **SET** key.



### ③ Operation mode setting

- Since it is in the timer operation mode, press the  $\blacktriangle$  or  $\blacktriangledown$  key to set the pulse operation mode.
- Once the pulse operation setting is completed, press the **SET** key.



### ④ Set the start year, month and day

- Set the start year, month and day by pressing the **YEAR**, **MON** and **DAY** key but  $\blacktriangledown$  key is applied when decreasing the previous value.
- Once setting the start year, month and day are completed, press the **SET** key (Cautious) within the year, the “-” indication is a setting for every year.



### ⑤ Set the end year, month and day

- Set the end year, month and day by pressing the **YEAR**, **MON** and **DAY** key but  $\blacktriangledown$  key is applied when decreasing the previous value.
- Once setting the end year, month and day are completed, press the **SET** key (Cautious) setting the year as the (-) for every year within the start year, month and day will fix the end year as (-) for every year.



### ⑥ Start time setting

- Set the start time by using the **hour**, **min** key but  $\blacktriangledown$  key is only used when decreasing the previous value.
- Once the start time setting is completed, press the **SET** key.



### ⑦ Pulse time range setting

- Set the pulse time range by using the **min** key but  $\blacktriangledown$  key is only used when decreasing previous value.
- Once the pulse time range setting is completed, press the **SET** key.



### ⑧ Return the yearly program setting

- Press the **PROG** key for more than 3 sec in order to return to the operation mode.

- Pressing the UP and DOWN key for more than 1 sec will change the time value quickly.

- When setting the year, it can set the year up to 2 years from the current year.

Example) if current year is 2008, it can be set as follows.

—  $\Rightarrow$  08  $\Rightarrow$  09  $\Rightarrow$  10  $\Rightarrow$  —  $\Rightarrow$  08  $\Rightarrow$  . . .

- When adding additional programs to the set program, please repeat steps from ② to ⑧.

- In the state where yearly program is being set, it can additionally set the weekly program.

- Yearly pulse setting is composed of 4 STEP and once setting is completed then it will display the number of remaining STEP that can be set.

## 🔗 Program editing (Program setting group)

### ■ Weekly program edit

It is possible to check the program that had been set in the weekly program edit mode and use the same revising method as the weekly program setting.

In order to delete the set program individually in the weekly program edit mode, press the **del** key for 1 sec then **del** indication will start to flicker. Here, press the **SET** key to delete the program.



① Enter into the weekly program edit mode

• Enter into the program setting mode by pressing the **PROG** key for more than 3 sec under operation mode and repeatedly press the **PROG** key to turn on the "Edit" indication and once the "YEEE" indication flickers, press the **SET** key.



② weekly program revise

• Revise it same as the weekly program setting method. – Displayed in the order of program input  
• Once the "End" indication flickers, it is indicating the completion of program edit. – Pressing the **SET** key will return to the EDIT mode.



③ weekly program delete

• In order to individually delete the weekly program, press the **del** key for 1 sec then the "dEL" indication will start to flicker. Here, press the **SET** key to delete the program.

- Pressing the **PROG** key in the middle of revising the weekly program, it will cancel the work and return to the weekly program EDIT mode.
- Unable to revise the operation mode (timer, pulse, cycle)

■ Yearly program edit

It is possible to check the program that had been set in the yearly program edit mode and use the same revising method as the yearly program setting.

In order to delete the set program individually in the yearly program edit mode, press the **del** key for 1 sec then "dEL" indication will start to flicker. Here, press the **SET** key to delete the program.



① Enter into the yearly program edit mode

• Enter into the program setting mode by pressing the **PROG** key for more than 3 sec under operation mode and repeatedly press the **PROG** key to turn on the "Edit" indication and once the "YEA-" indication flickers, press the **SET** key.



② Yearly program revise

• Revise it same as the yearly program setting method. – Displayed in the order of program input  
• Once the "End" indication flickers, it is indicating the completion of program edit.  
– Pressing the **SET** key will return to the EDIT mode.



③ Yearly program delete

• In order to individually delete the yearly program, press the **del** key for 1 sec then the "dEL" key will start to flicker. Here, press the **SET** key to delete the program.

- Pressing the **PROG** key in the middle of revising the yearly program, it will cancel the work and return to the yearly program EDIT mode.
- Unable to revise the operation mode (timer, pulse).

🔊 Delete all programs

■ Delete all weekly programs

- Enter into the program setting mode by pressing the **PROG** key for more than 3 sec within the operation mode and repeatedly press the **PROG** key repeatedly then "CLr" indication will be turned on and "YEEE" indication will start to flicker. Here, press the **SET** key.  
– Pressing the **PROG** key one more time will make it possible to delete all yearly programs. ("YEA-" indication flickers)
- Select the port 1 and port 2 by using ▲ or ▼ key in the weekly program setting mode
- Pressing the **SET** key for more than 3 sec will only erase the program in the selected port. ("End" indication means complete of work)



■ Delete all yearly programs

- Enter into the program setting mode by pressing the **PROG** key for more than 3 sec within the operation mode and repeatedly press the **PROG** key then "CLr" indication will be turned on and "YEA-" indication will start to flicker. Here, press the **SET** key.
- Select the port 1 and port 2 by using ▲ or ▼ key in the yearly program setting mode.
- Pressing the **SET** key for more than 3 sec will only erase the program in the selected port. ("End" indication means complete of work)



## Program test

Able to check the actual time and day for output start and output end about the set weekly program for 1 week period.



### ① Enter into the program test setting

- Enter into the program setting mode by pressing the **PROG** key for more than 3 sec within the operation mode and repeatedly press the **PROG** key until "E E S L" indication starts to flicker. Here, press the **SET** key.



### ② Start time indication

- "E E S L" indication flickers and the start time regarding the first output operation time of set program will be displayed.
- In this state, pressing the **SET** key will display the end time.



### ③ End time indication

- "E E S L" indication flickers and the end time regarding the first output operation time of set program will be displayed.
- In this state, pressing the **SET** key will display the next output operation time.



### ④ End the program test

- Able to check the output operation time for 1 week period by pressing the **SET** key repeatedly
- Once the output operation time of set program completed, "E n d" indication will flicker.

## Function setting (function setting group)

### ■ Current time setting (Refer to the time adjustment method)

### ■ Yearly holiday setting

Without changing the program it blocks the output by assigning the yearly holiday date.

Users do not have to change the set program or operate the output switch forcibly because once the yearly holiday setting date passes, it automatically cancels the function.

Example) set holiday from 2008/7/30 to 8/3 and in the next year, it will be cancelled.



### ① Enter into the yearly holiday setting

- Enter into the function setting mode by pressing the **FUNT** key for more than 3 sec within the operation mode and pressing the **PROG** key one more time will flicker the "H d R Y". Here, press the **SET** key.



### ② Yearly holiday start year, month and day setting

- Set the start year, month and day by using the **YEAR**, **MON** and **DAY** key. But,  $\blacktriangledown$  key is applied when decreasing the previous value.
- "START" indication flickers.
- Once completing the start year, month and day setting, press the **SET** key. Cautious) in the year, "--" indication is yearly setting.



### ③ Yearly holiday end year, month and day setting

- Set the end year, month and day by pressing the **YEAR**, **MON** and **DAY** key but  $\blacktriangledown$  key is applied when decreasing the previous value.
- "STOP" indication flickers.
- Once completing the end year, month and day, press the **SET** key.

Cautious) setting the year as the (- -) for every year within the start year, month and day will fix the end year as (- -) for every year



### ④ Return to the yearly holiday setting

- " - - . - - " indication flickers, users can perform additional setting.
- In order to return to the operation mode, press the **PROG** key for more than 3 sec.

- Yearly holiday setting can be set from current date to date after 2 years 12/31 and once passes the assigned date, it will automatically cancel the function.
- Able to set 16 times for the yearly holiday setting and if it is already being set, it will display with the current program and able to set additionally by pressing the **SET** key until " - - . - - " is displayed. (able to revise the yearly holiday)
- In order to delete the holiday setting, press the **del** key for 1 sec then " d E L " will flicker. Here, press the **SET** key to delete the program.

### ■ Season switch setting

Depending on the season switch setting, weekly program automatically changed.



① Enter into the season switch setting

- Enter into the function setting mode by pressing the **FUNT** key for more than 3 sec within the operation mode and move to the "SE5n" setting screen by pressing the **PROG** key repeatedly.
- Once the "SE5n" indication is displayed, press the **SET** key.



② Season switch setting selection

- Change OFF indication to the ON indication by using ▲ or ▼ key.
- Once setting is completed, press the **SET** key.



③ Season period setting

- Move to the season period setting mode by pressing the **PROG** key.
- Since it is in the season period setting mode, press the **SET** key.



④ Season selection

- Select the season among S1, S2, S3 and S4 by using ▲ or ▼ (select "S1").
- Once selecting the season, press the **SET** key.



⑤ Start month and day setting

- Set the start month and day by using the **MON** and **DAY** key, but ▼ key is only used when decreasing previous value.
- **START** indication flickers
- Once the start month and day setting is completed, press the **SET** key.



⑥ End month and day setting

- Set the end month and day by using the **MON** and **DAY** key, but ▼ key is only used when decreasing previous value.
- **STOP** indication flickers
- Once the end month and day setting is completed, press the **SET** key.



⑦ Return to the season switch setting

- In order to return to the operation mode, press the **PROG** key for more than 3 sec.

• Season switch setting is for the weekly program. (Not yearly program).

Cautious) if the weekly program had already been set, changing the season switch setting from OFF to ON or ON to OFF will delete the all settings in the weekly program so please be cautious.

• If season period duplicated, it goes as following order. S1(S2(S3(S4

Example) Set S1 (1/1~12/31), S2 (7/20~8/1) then it goes as following order.

### ■ Summer time setting

Switching manually and switching automatically are possible in the summer time setting  
Setting the automatic switching period (time) will provide more convenient usage.



① Enter into the summer time setting

- Enter into the function setting mode by pressing the **FUNT** key for more than 3 sec within the operation mode and move to the "d5t" setting screen by pressing the **PROG** key repeatedly.
- Once "d5t" is indicated, press the **SET** key



② Summer time selection

- Change OFF indication to the AUTO indication by using ▲ or ▼ key.
- Once setting is completed, press the **SET** key



③ Summer time period setting

- Move to the summer time period setting mode by pressing the **PROG** key.
- Since it is in the summer time period setting mode, press the **SET** key



④ Start month and day setting

- Set the start month, day by using the **MON** and **DAY** key but  $\blacktriangledown$  key is only used when decreasing previous value.
- **START** indication flickers
- Once completing the start month and day setting, press the **SET** key



⑤ Start time setting

- Set the start time by using the **hour** key but  $\blacktriangledown$  key is only used when decreasing previous value.
- Once completing the start time setting, press the **SET** key

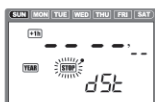

⑥ End month and day setting

- Set the end month, day by using the **MON** and **DAY** key but  $\blacktriangledown$  key is only used when decreasing previous value.
- **STOP** indication flickers
- Once completing the end month and day setting, press the **SET** key



⑦ End time setting

- Set the end time by using the **hour** key but  $\blacktriangledown$  key is only used when decreasing previous value.
- Once completing the end time setting, press the **SET** key



⑧ Return to the summer time setting

- In order to return to the operation mode, press the **PROG** key for more than 3 sec.

- External **+1h** key will not operate in case summer time is set as "AUTO".
- It is available to check or change the summer time period which is set previously.
- In case of Start time setting and End time setting, the value of [MIN] is fixed as "00 MIN"

■ Power backup operation setting

- Set "AUTO" in the power backup input setting then output will be operated according to the set program when re-supplying in the power after facing the electrical failure.
- Set "NOR" in the power backup input setting then the **POW** indication will start to flicker and the output will be maintained as OFF state disregarding the set program when re-supplying in the power after facing the electrical failure.
- Once the external input signal (BOOT) is supplied in, the **POW** indication will be turned off and output will be operated according to the program setting.

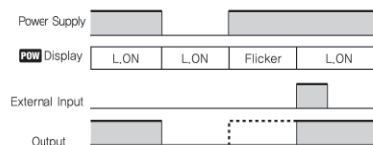

① Enter into the power backup operation setting

- Enter into the function setting mode by pressing the **FUNT** key for more than 3 sec within the operation mode and move to the "boot" setting screen by pressing the **PROG** key repeatedly.
- Once the indication "boot" is indicated, press the **SET** key.

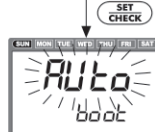

② Power backup AUTO setting

- Set as **Auto** by using  $\blacktriangle$  or  $\blacktriangledown$  key.
- Power backup will be set as Auto if pressing the **SET** key.

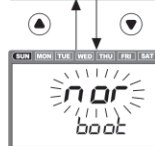

③ Power backup Normal setting

- Set as **nor** by using  $\blacktriangle$  or  $\blacktriangledown$  key.
- Power backup will be set as Normal if pressing the **SET** key.

- Please refer to the connection diagram for the power backup input (BOOT).
- For the input, please use the contact such as switch, relay and etc. (and for the voltage, please use the contact that can sufficiently current of 5V 0.1mA) (Min signal input range min 10 ms)

## Simple function (use front panel key)

### ■ Summer time external input

In the operation mode, pressing the **+1h** key for more than 1 sec will make the time either one hour faster or slower.



#### ① Summer time application

- In the operation mode, pressing the **+1h** key for more than 1 sec will turn on the “**+1h**” indication and the current time will become 1 hour faster.



#### ② Summer time cancellation

- In the operation mode, pressing the **+1h** key for more than 1 sec will turn off the “**+1h**” indication and the current time will become 1 hour slower

- Summer time can be set as yearly type (refer to the summer time setting)

Cautious) if setting the summer time as ON, “**+1h**” the key will not be operated

### ■ 12/24h indication switch

In the operation mode, every time when you press the **12/24h** key for more than 1 sec, it will change the current time displaying method.

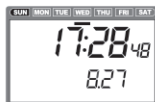

#### ① 24 hour display => AM/PM 12 hour display

- In the operation mode, pressing the **12/24h** key for more than 1 sec will change from “24hour display” type to the “AM/PM 12 hour display” type.



#### ② AM/PM 12 hour display => 24 hour display

- In the operation mode, pressing the **12/24h** key for more than 1 sec will change from “AM/PM 12 hour display” type to the “24 hour display” type.

• Time display type in the operation mode: 24h display type => 0:00~23:59, 12h display type => AM0:00~11:59 / PM 0:00~11:59

### ■ Switch the screen indication

In the operation mode, every time when users press the **mm.dd** key for more than 1 sec, information in the second indicator will be changed.



#### ① current month / day display

- 1st indicator : display the current time (hour, min and sec)
- 2nd indicator : display the current month/day (month and day)

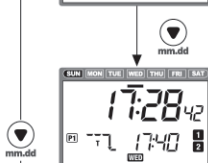

#### ② display the operation time after output 1

- 1st indicator : display the current time (hour, min and sec)
- 2nd indicator : display the operation time after output 1 (hour, min)

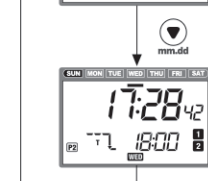

#### ③ display the operation time after output 2

- 1st indicator : display the current time (hour, min and sec)
- 2nd indicator : display the operation time after output 2 (hour, min)

- Default value : “current month/day display”.

• After setting the program, the set value displayed in the screen will be applied to the 2nd indicator within the operation mode. (display current month and day)